

- Residential AC
- Commercial AC
- Marine
- RV

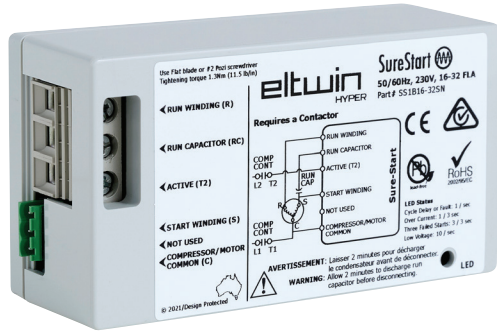

## INSTRUCTION GUIDE SSxB SERIES / SINGLE PHASE

### Parts List:

- 1 x SureStart Soft starter
- 1 x Brown Wire
- 1 x Red Lead
- 1 x Mounting Bracket
- 1 x Blue Wire
- 1 x Green Connector
- 1 x Black Wire
- 1 x Pack of two Ferrules

### SureStart® 120/240V HVAC installation - SSxB Series:

This model SureStart® functions only as a soft starter, a contactor is still required. This model can be suitable for a wide range of applications. Some degree of care is needed to determine the correct wiring.

### Caution & Warning:

- 1 All voltage to equipment **MUST** be disconnected before removing any devices.
- 2 Allow 2 minutes to discharge run capacitor before disconnecting.
- 3 Do not swap the Run & Start Windings.
- 4 Prior to installation, be sure all start capacitors & start relays, along with hard-starters and/or any other start-assist devices, are removed.
- 5 The start capacitor is built into the soft starter.
- 6 Loose terminals can lead to heating & subsequent damage to the soft starter. As per, UL508 standard, ensure below tightening torques.
- 7 OPENING OF THE SOFT STARTER UNIT WILL VOID THE WARRANTY!

### LED Flash Codes:

Flash Code	Definition	Time to re-start attempt
Rapid Flash (10 / 1 sec)	Low Voltage	3 min
Triple Flash (3 / 3 secs)	Lockout on 3 failed starts	50 min
Slow Flash (1 / 3 secs)	Lockout on overcurrent	10 min
Steady Flash (1 / 1 sec)	Cycle delay / Faults	3 min

[NOTE: LED fault indicator remains off in normal running mode.]

### Field Wiring Specifications:

**Wire Range:** 8 to 12 AWG Cu, stranded, for terminals (Run Winding (R) and Active(T2))

12 to 16 AWG Cu, stranded, for terminals (Run Capacitor (RC), Start Winding (S), and Compressor/Motor Common (C), these are supplied)

**Tightening Torque:** 11.5 LBS-IN LARGE TERMINALS, 4.5LBS-IN SMALL TERMINALS.

Field wiring conductors shall be rated 167°F [75°C]

Minimum end use enclosure size: 10" x 8" x 6"

• **CRIMP CORRECT SIZED FERRULES TO ENSURE PROPER TERMINATION**

• **INSERTION LENGTH OF FERRULE "D": 11 ± 1 MM (0.43 ± 0.04")**

• **CABLE BEND RADIUS "R" > 38MM (1.5") MINIMUM**

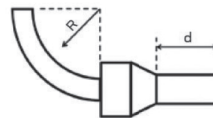

### Sample Wiring Schematic

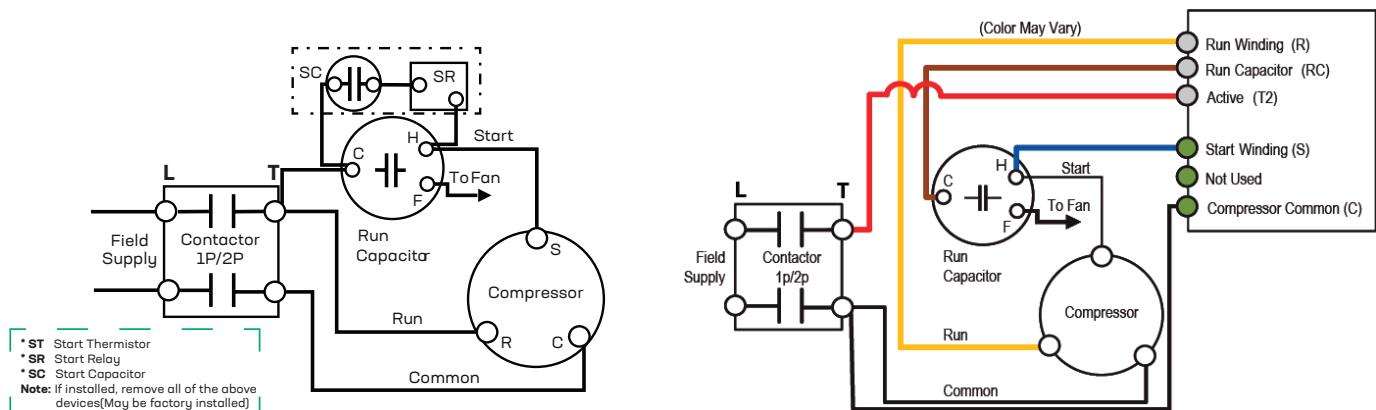

- Residential AC
- Commercial AC
- Marine
- RV

INSTALLATION INSTRUCTIONS



1] Turn off all power to the HVAC unit at the circuit breaker..



2] Secure the mounting bracket for the SureStart inside the control

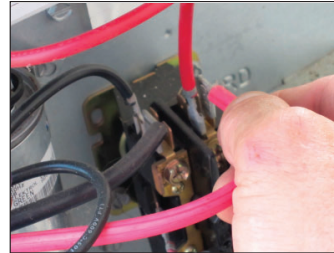

3] Remove the compressor Run wire from the contactor or Run Capacitor terminal, as applicable.



4] Strip the compressor Run wire a least 1/2 in.\* Crimp appropriate size Ferrule (supplied) onto it.

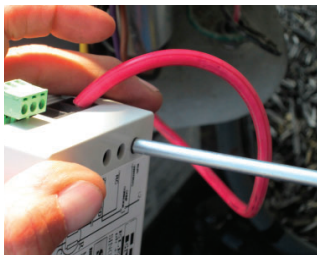

5] Attach the compressor Run wire to the SureStart Run Winding terminal.



6] Attach the brown wire supplied with the SureStart to the Run Capacitor terminal on the SureStart.



7] Identify the cable connecting the contactor and the Run Cap. Remove this connection to the Run Cap Attach the flagged end of the brown wire to the same terminal of the Run Cap#1.



8] Attach the black wire (supplied) to Compressor Common on the SureStart green terminal connector.

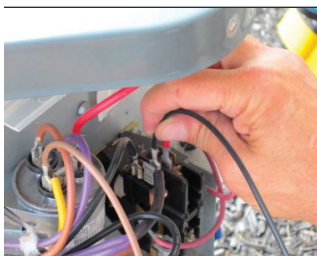

9] Attach the flagged end of the black wire to the Compressor Common on the "T" side of the contactor.

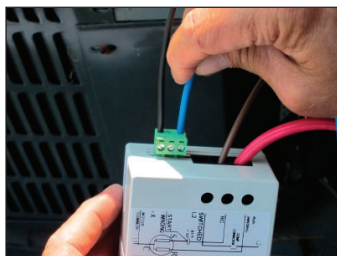

10] Attach the blue wire (supplied) to the Start Winding on the SureStart green terminal connector.

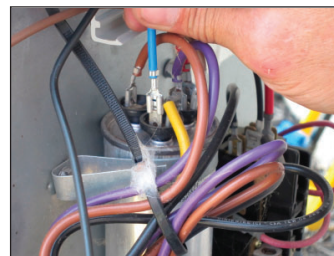

11] Attach the flagged end of the blue wire to the other terminal#2 of the Run Capacitor. Ensure that this terminal on the capacitor also joins to the Start Winding of the compressor.



12] Attach the red wire (supplied) to the Active terminal on the SureStart.

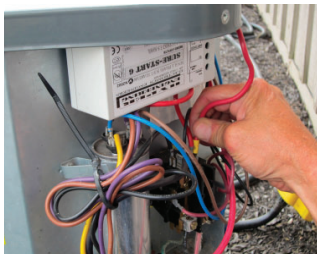

13] Remove the loose wire (from Step 7) from the active input of the contactor and attach the stripped end of the Active wire in its place.

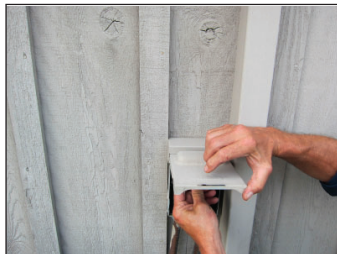

14] Apply power to the equipment and cycle#3 to ensure proper operation.

NOTE:

- #1 This is the Common (C) terminal for Dual Compressor/Fan Capacitors.
- #2 This is the Herm (H) terminal for Dual Compressor/Fan Capacitors.
- #3 The SureStart device could take up to six (6) starts to optimize

**WARNING**

This product can expose you to chemicals including Bisphenol A and Ethylene Glycol, which are known to the State of California to cause cancer or birth defects or other reproductive harm. For more information, go to [www.P65Warnings.ca.gov](http://www.P65Warnings.ca.gov)

All SureStart products are complaint to RoHS, REACH, 3TG and SCIP regulations.

Conforms to UL 60947-1 & UL 60947-4-2  
Certified to CSA C22.2 #60947-1 & #60947-4-2

**CAUTION**

SureStart® must be installed in a location that ensures that the external heat from a hot gas line, compressor discharge piping, or similar heat source will not cause damage. Minimum 3" (76 mm) clearance is recommended.

able for use on a circuit capable of delivering no more than 5000rms metrical amperes, 240 volts maximum, when protected by a non-time delay fuse or circuit breaker rated 80A, or a time delay fuse rated 70A. The ce does not provide current limiting control or equivalent.